

Code	48TOP12A1	Uses	Household
Family	TOP 1-2-3		
Group	Clear water drainage		
Typology	Submersible		

Application limits

Liquid Type	Clear Water
Minimum liquid temperature	0 °C
Maximum liquid temperature	40 °C
Maximum Chlorine Content	- ppm
Maximum Sand Content	- ppm
Manometric suction lift	0 m
Maximum immersion depth	3.00 m
Maximum Ambient Temperature	- °C
Minimum Ambient Temperature	- °C
Maximum Working Pressure	- bar

Duty Point

Flow rate (actual)	0.000 l/min
Head (actual)	0.000 m

Pump nameplate data

Flow rate	20 - 220 l/min
Head	8 - 1 m
Maximum head	8.5 m
Minimum head	1 m
Minimum Efficiency Index	-

Motor nameplate data

Voltage	220-240 V
Phases	1
Frequency	50 Hz
Rotation Speed	2900 rpm
Rated output power	0.37 kW
Rated Current	2 A
Input power P1	0.45 kW
Efficiency grade	Undefined
Capacitor	10 µF
Capacitor Voltage	450 V
Insulation Class	F
Enclosure class IP	X8

Construction and safety standards

The pumps are complete with:

- 5 m long power cable
- float switch

AVAILABLE ON REQUEST:

TOP 2-3 LA pumps intended for use with aggressive liquids

- EN 60335-1, IEC 60335-1
- EN 60034-1, IEC 60034-1

Connections

Type of connection	Gas threaded
Size of suction connection	-
Size of delivery connection	1 1/4"

Input Data

Rated flow rate (requested)	0.000 l/min
Rated head (requested)	0.000 m
System geodetic head	0.000 m
System friction losses	0.000 m
NPSH Available	0.000 m
Liquid	Water
Temperature	0 °C
Density	1000 kg/m ³
Kinematic Viscosity	1.78 mm ² /s
Vapour Pressure	673 Pa

Other Pump Data

Max Sound Pressure Level (1 m)	- dBA
Horizontal installation	No
Solids free passage	10.00 mm

Performance

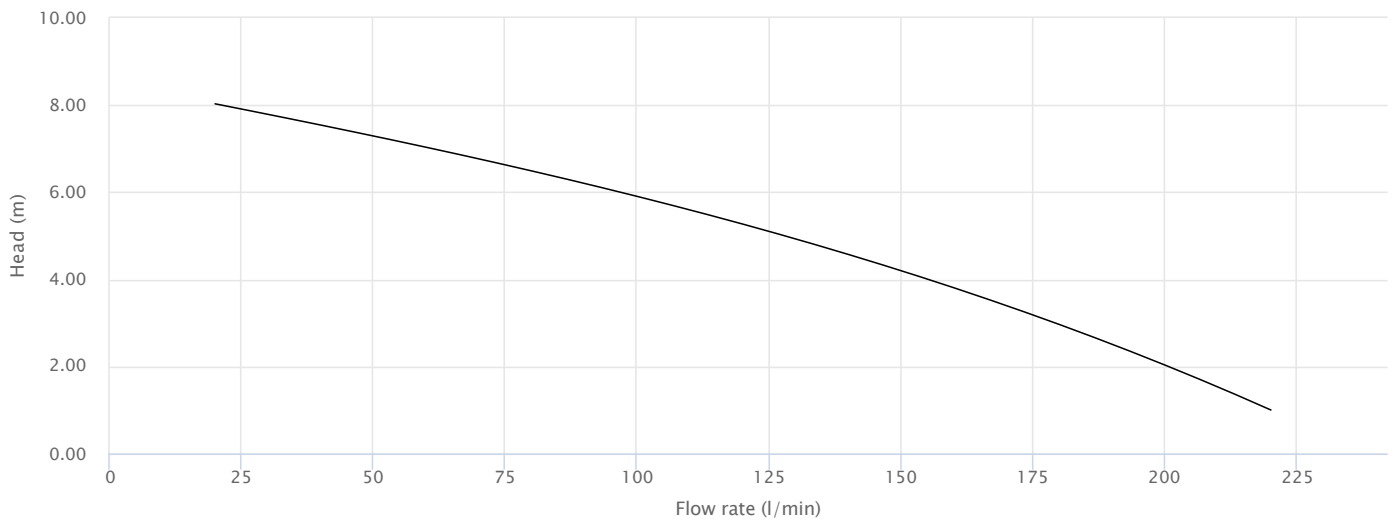

Construction

Bearings

Motor bearing - pump side	6201 ZZ
Motor bearing - opposite side	6201 ZZ

Shaft Seal

Seal Type	Double: Mechanical seal and Lip seal in an oil chamber
Motor Side Model	Lip seal
Diameter MS	12
Elastomer MS	NBR
Reducer DN1=450 DN2=350	STA-12R
Diameter PS	12
Stationary Ring PS	Ceramic
Rotating Ring PS	Graphite
Elastomer PS	NBR

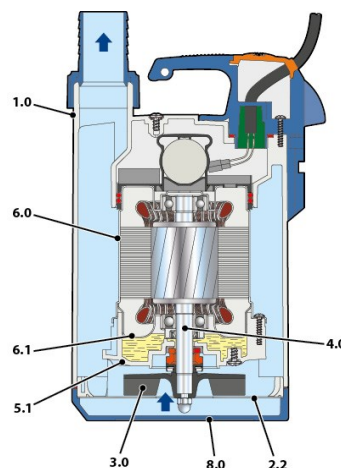

Materials

1.0 - Pump casing	Reinforced technopolymer
2.2 - Suction Cover	Stainless steel EN 1.4301 (AISI 304)
3.0 - Impeller	Reinforced technopolymer
4.0 - Pump Shaft	Stainless steel EN 1.4057 (AISI 431)
5.1 - Diffuser	Reinforced technopolymer
6.0 - Motor casing	Stainless steel EN 1.4301 (AISI 304)
6.1 - Motor Cover	Stainless steel EN 1.4301 (AISI 304)
8.0 - Suction Strainer/Filter	Reinforced technopolymer

Dimensions

DN2	a	d	h	h1	p	x	Kg
	[mm]						
1 1/4"	152	14	260	240	350	350	5

